



Metal Work Mechatronics



Metal Work.

A leader in pneumatic automation for 50 years

Metal Work has its roots in traditional mechanical engineering and has grown over time following natural technological development. Today, the Metal Work Group comprises R&D and production units that are equipped with fully-fledged automated systems.

Metal Work Mechatronics is the result of a half-century of experience in the design and manufacture of top quality innovative components, the synthesis of latest-generation technologies and services applied to industrial automation.

The team of the Metal Work Mechatronics consists of engineers and companies belonging to the Metal Work Group that have pooled their expertise to offer the world of automation and automated mechanical engineering a wide range of products and advisory, design and assistance services gauged to meet customer specific requirements.

Metal Work has been synonymous with the manufacture of pneumatic components for over 50 years.



Air treatment units



Fittings and accessories



Pneumatic, electropneumatic, mechanical valves



Pneumatic and electrical actuators

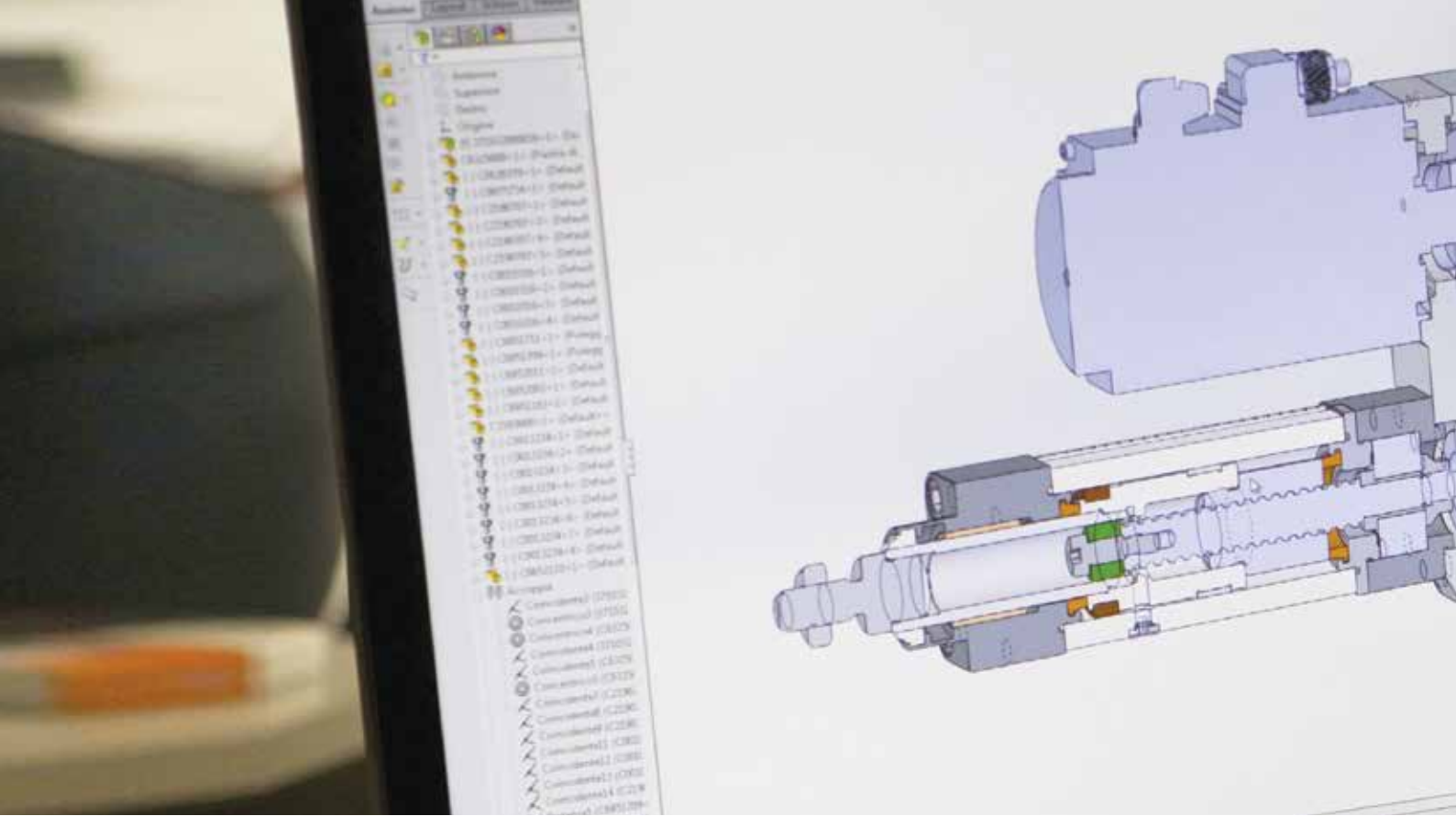

Metal Work Mechatronics: know-how and synergy at your service

Metal Work Mechatronics encompasses the expertise and solutions developed by the companies belonging to Metal Work Group.

Metal Work Sales Network

The technical expertise and customer service at Metal Work goes well beyond the production units. The Group's team of mechanical engineers and sales network, consisting of 46 Metal Work Service branches in Italy and worldwide, have an in-depth knowledge of the product and its applications that is fuelled by in-field data acquired day after day and supported by latest-generation IT tools, such as CRM. The extensive know-how of the sales network provides active support for the design, development and operation of pneumatic panels and hydraulic control units, as well as the design and installation of electronic control systems (system integrators) directly at customers' premises.

Alfameccanica

The flagship of the Metal Work Group, Alfameccanica produces component parts for the handling industry, and over the years it has developed its own range of products, including grippers, actuators and guide units for cylinders - all featuring premium quality, top performance and accurate design.

The product range has recently been complemented and extended by V-Lock products, the brainchild of effective cooperation with the Swiss company Montech, a historical brand in the production of component parts for the handling industry.

The range of standard product is completed by the series of special actuators that are designed and developed to meet specific customer requirements, using special superior quality aluminium alloys or stainless steel.



Fluid Force

Fluid Force comes in where pneumatics encounters hydraulics. This dynamic business boasts decades of experience in the design and production of hybrid air-oil component parts. Hydraulic brakes used to regulate the motion of pneumatic, in-line and rotary actuators are a good example.

Over the years, Fluid Force has developed a series of complementary products, such as air-oil pumps or air-oil pressure multipliers.

The top mechanical skills and the high level of precision have made Fluid Force a benchmark in the Metal Work Group for the assembling of electric cylinders equipped either with standard motors or special motors.

Metal Work Automation

Metal Work Automation is the company in the Group that designs and develops assembly machines that are used by Metal Work to make its own components.

The Group's expertise and the entire range of products are accessible to customers and are continuously tested and assessed directly in the field. Skilled engineers carry out in-process analyses on a regular basis to improve the quality and performance of each component of the machines that are designed and developed in house.



Products / Electric cylinders

Series ELEKTRO ISO 15552

Elektro ISO 15552 cylinders are characterised by a connection interface complying with the relevant standard.

The piston rod extension is controlled by a system with a hardened screw and recirculating ball screw nut. The piston has a guide strip calibrated to reduce to a minimum the play and vibration during rotation of the ball screw.

This cylinder can be equipped with a built-in nonrotating system. The piston comes with magnets and the barrel has longitudinal slots for housing sensors.

The piston rod has an increased outside diameter and thickness to make it extra rigid and more resistant to radial and peak loads.

A system for greasing the screws is incorporated in the cylinders and numerous standard accessories can be used for their installation, including an intermediate hinge. The motor can be selected from an optimised range, which encompasses both STEPPING and BRUSHLESS motors. Special adaptor flanges, joints and drive systems can be provided if the customer wishes to use a particular brand of motor.



Series ELEKTRO ISO 15552 EK

The ELEKTRO ISO 15552 EK series stands out for some design choices that made it possible to reduce the length and cut costs, with a few different technical characteristics. A greasing system is incorporated to lubricate the screw/ball screw nut. Only a version with inline motor, which is shorter than the equivalent ELEKTRO ISO15552 cylinder, is provided.

A steel bracket to be fixed to the rear head, with an interface suitable for ISO 15552 cylinder accessories, is provided to be fixed to the cylinder from the rear side. The cylinder can be supplied with a STEPPING or a BRUSHLESS motor, with or without parking brake.



Series ELEKTRO SSC

The ELEKTRO SSC series differs from the ISO 15552 ELEKTRO series in some design choices, including the absence of the front and rear heads.

The cylinder is available with two defined strokes, 30 mm and 55 mm respectively.

The piston rod moves forwards by either the hardened and tempered steel screw and a ball recirculating screw nut or a stainless steel screw and technopolymer lead nut.

The cylinder is equipped with an anti-rotation system that can be easily removed as required.

A magnet is fitted to the piston rod to provide a limit switch signal and two separate lengthwise slots are provided on the cylinder body to accommodate the Square-type sensors.

An easily removable plate is attached to the cylinder body to facilitate re-lubrication of the screw.

The cylinder is available in either in-line or geared version.

The motor can be selected from among an optimized range, which includes both STEPPING and BRUSHLESS motors.

The most suitable drives for the motors are also provided.

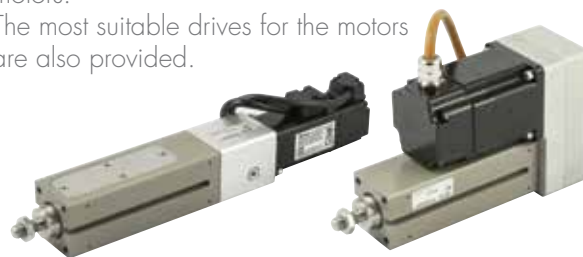

Series ELEKTRO ROUND DC

Round DC cylinders are the ideal solution for applications requiring the control of speed, thrust and acceleration. The DC motor is powered 24 VDC and is actuated by a simple On-Off control. It is designed for alternate "work-rest", non-continuous operation.





Products / Electric axes

Shak

The Shak belt-driven electric axis features excellent manufacture and a sturdy anodised aluminium extruded profile that ensure optimal rigidity. The slide is moved by means of adjustable castors running along hardened and tempered guides.

The slide is driven by a reinforced belt that is connected to the motor.

The Shak axis can mount either BRUSHLESS or STEPPER motors. The versions with a BRUSHLESS motor can be equipped with a speed gear unit, when you want to make of the most of the available torque.

Nozzles are also mounted on the moving plate for easy lubrication of the guides.

The extruded profile and the moving plate are fitted with a V-Lock interface with a dovetail for the easy fixing of the axis and other components, using QS or K elements.

In addition to standard drives, other brands of motor can be mounted if the customer so wishes. The homing position is identified by an inductive sensor included in the supply.



Two different sizes are available, SHAK 340 and SHAK 470, with pre-set standard strokes. For each size it is possible to choose the side on which to mount the motor (4 positions). A version with a smooth tree-type output, mounted in a pre-set position, is also available.

The cylinder can be mounted both horizontally and vertically. With vertical installation, it is advisable to use motors with a holding brake that only activates in the event of a power failure but not when there is a motor overload. For the correct operation of the brake, it is necessary to meet the limits required by the axial load curves according to the speed.

Among the accessories available there is a cable guiding system with a handy cable channel and bracket.

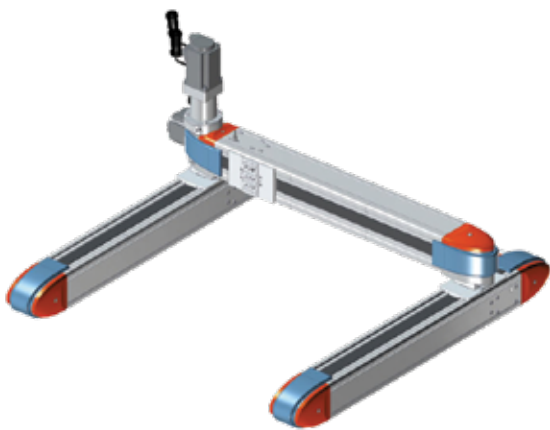

Shak Gantry

The Shak Gantry system is designed to form a portal made up of two parallel axes (drive X-axis and driven X-axis) surmounted by a transversal axis (Y-axis). Both axes are connected one to the other by means of an anodized aluminium shaft and two flexible couplings that compensate for any minor misalignments. The shape of both the couplings and the drive shaft is designed to facilitate disassembly.

The carriages of the drive axis and the driven axis (both with a V-Lock interface featuring a typical shape and grooves) move synchronously thanks to the drive shaft.

On the extruded body of both axes, the typical V-Lock dovetail is provided for easy fixing to the support structure, using QS elements.

The motion is the same as with the SHAK single axis and has the same advantages.

A Brushless motor with speed gear has been adopted as it ensures optimal load capacity without sacrificing the dynamics and speed performance typical of this product.

In addition to the standard drives proposed in the catalogue, the cylinder can be customised with the installation of other makes of motor. The homing position is identified by an inductive proximity sensor included in the supply.

Two sizes are available, SHAK GANTRY 340 and SHAK GANTRY 470, with standard pre-set strokes. For each size, it is also possible to choose on which side to mount the motors (RH or LH).

The SHAK GANTRY portal was designed and optimised for horizontal installation. On request, the motors can be supplied with a holding brake, which activates only in the event of a power failure but not when there is a motor overload.

Among the accessories available there is a cable-guiding system with a handy cable channel and bracket (in the version with motors on the left-hand side).

CANTILEVER - SVAK axis

The SVAK can be used as the Z-axis on the Cartesian portal. This belt-driven rodless electric actuator is characterised by the fact that the motor and reducer unit is integral with the carriage, instead of being fitted to one end of the extruded section on which the carriage slides. This solution is known as "cantilever". In the typical application, the carriage is fixed while the extruded section moves.

The SVAK can be used either horizontally or vertically, but the most common use is in vertical applications, which explains why the motor is supplied complete with a brake that causes the axis to remain still even when it is not electrically powered.

The SVAK uses the universal V-Lock modular system for fixing the carriage to external auxiliaries and the various components to one end of the extruded section.

The sides of the extruded section, which is made of anodised aluminium, houses two hardened and ground guides that slide on adjustable wheels that are integral with the carriage. The carriage is moved by a toothed belt, complete with a tensioning system. Guide lubrication nozzles are also provided on the carriage

The Svak axis uses a Brushless motor with a toothed belt 1:2 gear speed reducer for the pulleys. This design was opted for because it ensures excellent load capacities without sacrificing the typical dynamics and speed of this product.

In addition to the standard drive proposed in the catalogue, it is also possible to customise the cylinder by using other motors. The homing position is detected by an inductive proximity sensor included in the supply.

A cable guiding system with cable-carrying chain and mounting bracket is also available on request as an accessory.



CANTILEVER - VBK axis

VBK Series belt-driven rodless electric axis, specifically designed for use in applications where the motor unit remains stationary and the extruded profile moving (so-called cantilever solution). VBK has a load-bearing structure consisting of anodised aluminium extrusion profile and a linear guide system with rail and ball-recirculation pads.

Typical applications involve the axis being used vertically, for example as a Z-axis in a Cartesian portal, with a Metal Work BK Series Gantry or a SHAK Gantry. However, the VBK can also be individually, in either horizontal or vertical orientation.

A steel-reinforced polyurethane toothed belt provides drive transmission. The parabolic profile of the belt tooth ensures high efficiency, thereby reducing noise and vibration. The central body houses the drive unit consisting of a drive pulley and two idle rollers ("omega" configuration).

The axis, which can be ordered with a mm stroke, comes complete with a belt-tensioning system and channels for pad relubrication. Threaded holes and centring holes are provided on the central body and end caps, allowing multiple mounting options. The extruded block features the characteristic V-Lock

profile and an inner opening where cables and pipes can be routed.

The VBK axis is available with or without drive. The standard drive includes a brushless motor with a holding brake, combined with a precision planetary gearbox available in three different gear ratios. The motor unit can be mounted on either side of the central body, while the side without the motor is enclosed by a safety cover.



SK axis

Screw-driven rodless electric axis with a load-bearing frame made of anodised extruded aluminium, which gives the cylinder optimal torsional and flexural rigidity. It comes in two sizes, SK-0 and SK-2.

For the SK-0 size, two V-shaped guides run directly on the outer edge of the extruded section and support a moving carriage fitted with two wear-resistant acetal resin pads. Due to pad support, the carriage only conveys axial forces to the feed system consisting of a self-lubricating techno-polymer nut and a lead stainless steel screw.

Size SK-2 features a carriage driven by two sturdy preloaded ball recirculation pads that ensure great accuracy of movement.

The carriage features an interchangeable fixing interface plate, which can be ordered with V-Lock attachments.

Various STEPPING and BRUSHLESS motor drives are available with optional motor brake and/or built-in encoder.



BK axis

Electric belt-drive rodless axis with a bearing structure made up of anodized extruded aluminium. The axis is available in two sizes, BK-1 and BK-2. The slide interface is characterised by the V-Lock profile complete with threaded holes.

The BK-1 size is available in two variants: the "Medium" uses castors running along hardened and tempered guides with double-row ball bearings, and the more performing "Heavy" version consists of a guiding system with a rail and ball recirculation pads.

The BK-2 size is available in two variants, both with rail and ball recirculation pads, the "Heavy" type has two pads and the "Heavy XL" has a longer slide and four pads.

BRUSHLESS and STEPPING motors are available, with optional motor brake and/or built-in encoder.



CS slide

Compact electric slide, equipped with a guideway and a ball-recirculating pad capable of withstanding high radial loads on the piston rod. Available in the 55 mm stroke, the slide in the ELEKTRO CS series features the same technical choices as those made in the ELEKTRO SSC series in terms of extreme compactness and pure design, including the wear-resistant aluminium body.

Driven by a hardened steel screw and recirculating ball screw nut, the stainless-steel piston rod is coupled, via a rigid aluminium structure, to a recirculating pad that runs along a guide rail integral with the main body.

The ELEKTRO CS series slide is available in either a standard profile version or a V-Lock interface version. The electric motor can be either connected in-line with the slide or by means of a transmission system; in the latter case, three different configurations are available. The motor can be selected from an optimised range comprising both STEPPING and BRUSHLESS motors.



RBA rotary actuator

Compact electric rotary actuator providing unlimited rotation angle in both directions.

Motor power is transmitted to the load by a toothed belt drive with a specific gear ratio, thereby ensuring high performance in reduced dimensions. The belt is maintained at the correct tension by an adjustable eccentric tensioner.

The driven pulley features a through-hole that allows pipes and cables to pass through to facilitate integration with other devices.

This actuator can be used either as a fixed rotary table or applied to a moving axis, like the VBK, thereby greatly increasing the range of applications. The RBA is available with or without a motor drive.

The standard drive of the RBA makes it possible to choose between a brushless motor and a stepping motor with encoder. Both versions are available with a holding brake.





Products / Control devices

e.Motion

e.Motion is an electronic programmable device designed to control electric pulse train motors, for either brushless or stepper motors.

This is the ideal solution for customers who are not familiar with programming or for applications where PLC control is not available.

Using an easy, intuitive user interface and a simple yet comprehensive programming language, with e.Motion you can fully control any electric axes, regardless of whether Metal Work motors or other makes are used.

e.Motion hardware and software have been entirely developed by Metal Work, which allows full customisation and adaptation to all possible user requirements.



The special sizing software used by our engineers makes it possible to offer the customer personalised advice on choosing the best suitable axes among those offered by Metal Work, as well as full assistance in developing the e.Motion software, by providing all the information required to start up the application.

e.Drive

e.Drive is an independent system, ideal for “stand alone” applications not requiring the use of a PLC.

It can be used to control, easily and intuitively, electric cylinders that use STEPPER motors at a rated current of up to 6A, two phases, with four, six or eight output wires.

It connects up to a PC via a USB port and offers a motion control configuration, programming and debugging environment, thus allowing the user to create complex work cycles as it can handle both digital and analogue inputs and outputs, thanks to a user-friendly language (MW DRIVE).

It comes with two electronic boards housed in a metal box that has been designed for fixing onto a wall or, with an accessory, to a DIN rail and is equipped with removable screw connectors for wiring. The electronic boards can control both the logic “motion control” stage and the power supply stage.



The power stage consists of a mini-step bipolar chopper drive. The e-Drive system features a supply voltage of up to 55VDC for the power supply side and 24VDC for the logic side, compact dimensions and great flexibility of use.

e.Direct

Today a new e.direct drive for DC motors is available. The new e.direct drive has been developed specifically for the control of direct current motors (24 VDC) applied on Metal Work cylinders, for example on ELEKTRO ROUND DC Series cylinders.

It is a simple and direct drive which allows you to easily control an electric cylinder and which has the basic functions for connection to a control push-button panel and to limit switch sensors. The drive also allows you to adjust the speed and to read Hall sensor encoders.



The control software, pre-installed in the drive, prevents electromechanical stress on the motor, both during acceleration and braking. Moreover, it allows a precise stop avoiding unwanted extra travel.



Products / Actuators

In a typical automated mechanical engineering application, our cylinders and electric axes are a perfect complement to our range of grippers, in-line axes and pneumatic rotary actuators.

In-line actuators

Among in-line actuators, worthy of mentioning are our compact cylinders on bronze guide, ball recirculation bushes or sleeves, which are available in the version with or without cushioning; the guide units for ISO 15552 cylinders or 6432, with pneumatic, elastic or hydraulic stops.

Metal Work offers a full range of slides, guided in-line actuators, two- or multiple position rotary actuators, two- or three-jaw parallel or angle grippers.

Flat slides type S10, S11 and S12; precision slides S13 and S14; rodless cylinders with ball recirculation guide and shoe.



CMPGK compact guided cylinder

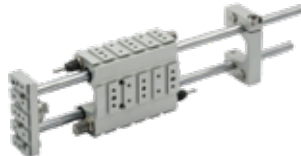

GD-K V-LOCK guide unit



S13 slide



LEPK Quick & Place

Rotary actuators

Moving on to rotary actuators, our robust, powerful R1s, for torques up to 120 Nm are worth mentioning.

Not to mention the DAP-Ks, which offer the possibility of using 4 adjustable stop positions.

Or again our R3 rotary actuators, with spring stops or shock-absorbers.

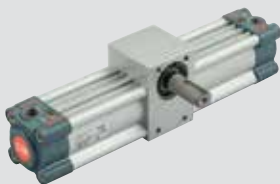

R1



R2



R3



R5



DAP-K



Products / Grippers

Metal Work production comprises a wide range of grippers:

- parallel with two parallel jaws: P1, P2, P3
- for long strokes: P4 and GPL-K
- with three parallel jaws: P12
- with two hinged jaws: P7
- toggle type: P9



P1



P2



P3



P4



GPL-K



P7



P9



P12



Custom products

Alfameccanica turns out thousands of custom products made of either aluminium, alloy steel or stainless steel, which are studied jointly with the customer according to specific requirements.



Piece gripping unit with suction cup



Locking cylinder with 90° disengagement rotation



Plate locking clamp



Piece locking system with rotating release, with hybrid feeding



Stopper cylinder and piece locking



Compact guided cylinder



Compact multi-fixing cylinder



Cylinder \varnothing 125 with piston rod 60



Short stroke mini



Compact mini



Stopper



Products / EB 80

Driven by customers, designed by Metal Work

The EB 80 is the result of lengthy research aimed at understanding customer needs and converting them into solutions. It is an electro-pneumatic system that encompasses solenoid valves, power supply, digital or analogue input or output signal control in a single unit.

The EB 80 can accommodate multi-function pneumatic solenoid valves with connections in the diameter range of 4, 8 and 10 mm. Flow rate up to 1200 Nl/min (\varnothing 10). The maximum number of controls for valves is 38 with electric multi-pole connection, and 128 with field bus connection. The signal management modules can handle up to 128 DI+128 DO+16 AI+16 AO. Patents and utility models ensure protection of the most innovative solutions.

The EB 80 stands out for the quality of materials used and accurate manufacture, which results in a highly reliable product. It is very easy to configure, which makes it a highly customisable solution.



Reliability



The environment and energy saving



Customisation



Warehouse and spare parts management



Certifications



Maintenance



Performance



User interface and use



Product range



THE EB 80 WORLD

ELECTRICAL CONNECTION - E											
E025	E044	E0EN	E0EC	E0PN	E0CN	E0PB	E0PL	E0IO	E0LK	E0CC	E0AD
EB 80 25-pin electrical connection	EB 80 44-pin electrical connection	EB 80 Electrical connection EtherNet/IP	EB 80 Electrical connection EtherCAT	EB 80 Electrical connection Profibus IO	EB 80 Electrical connection CANopen	EB 80 Electrical connection Profibus-DP	EB 80 Electrical connection Ethernet POWERLINK	EB 80 Electrical connection IO-Link 32 IN/32 OUT	EB 80 Electrical connection IO-Link 64 OUT	EB 80 Electrical connection CC-Link IE Field Basic	Additional electrical connection EB 80

VALVES											
Z	L	W	L	V	K	O	G	J	R	N0	Y8
2 valve 2/2 NC	2 valve 3/2 NC (vale come 5/3 CC)	2 valve 3/2 NO (vale come 5/3 CC)	3/2 NC + 3/2 NO	5/2 monostabile	5/2 bistabile	5/3 CC	3/2 NC alta portata	3/2 NO alta portata	Valvola sezionatrice di circuito	Falsa valvola	Bypass

SIGNAL MODULE - S							
S01	S02	S03	S04	S05	S06	S07	S08
EB 80 module with 8 MB digital inputs	EB 80 module with 8 MB digital outputs	EB 80 module with 6 MB digital outputs + electrical supply	EB 80 module with 4 MB analogue inputs	EB 80 module with 4 MB analogue outputs	EB 80 module with 16 digital terminal block inputs	EB 80 module with 16 digital terminal block outputs	EB 80 module with 4 MB analogue inputs for temperature measurement

CLOSED END-PLATE - C		
C1	C2	C3
Closed end-plate for islands with multi-pole connector	Closed end-plate for islands with fieldbus	Closed end-plate for electrical connection of islands with fieldbus to additional islands

INTERMEDIATE SUPPORT - M		
M...Z0	M...Z	M...Z...
Intermediate module - Silenced relief	Intermediate module - Conveyed relief	Intermediate module - Separate relief

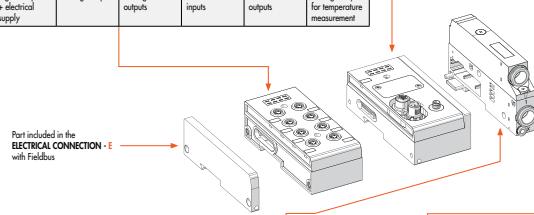

COMPRESSED-AIR SUPPLY - P			
P...Z00	P...Z...	P...Z0	P91Z90
Compressed air supply - Silenced relief	Compressed air supply - Conveyed relief	Compressed air supply - Separate reliefs	Module for electric version only

PROPORTIONAL PRESSURE REGULATOR - A	
A40 Z 0	A41 Z 0
Base part 1 pass-through local outlet	Base part 1 sectioned in-series regulation

BASES FOR VALVES - B	
B3...0	B4...0
3-position base for valves	4-position base for valves

Y-FITTING
R2
Y-fitting

MULTI-FUNCTION MODULE
Fittings with pneumatic functions



Products / Proportional regulators and flowmeters

Regulators Regtronic

The proportional regulators in the REGTRONIC series are used to precisely regulate the pressure in a system, the value of which varies with the input command.

Remote control regulators are controlled via either an M12x1 cable and a Volt, mA and RS232 connector, or an IO-Link.

Regulators with a display can be controlled via a cable or directly using the keys below the display. The pressure value and a series of information and diagnostics are visible at all times on the graphic display.

The user-display interface LEDs and buttons are all on one side. The programming and reading software is simple and intuitive.

Pressure control takes place in a "closed loop", via:

- an electronic precision pressure sensor that measures the downstream pressure;
- a control system that compares it with the set pressure;
- two mini-solenoid valves that adjust the pressure to reach the set value.



Flowmeters Metal Work Serie Flux

The family of Metal Work flowmeters, FLUX Series consists of three versions: FLUX 0, FLUX 1, FLUX 2, FLUX 3 and FLUX 4.

Starting from the miniaturized version FLUX 0 which can be used to measure flow rates up to 200 NI/min, we arrive at the new versions which measure flow rates up to 15000 NI/min (FLUX 4).

They have a sturdy anodised aluminium body with inlet and outlet threads of G 1/2" (FLUX 1), G 1" (FLUX 2), G 1/2" (FLUX 3) and G 2 (FLUX 4) onto which the measurement and control electronics are fitted. A flow linearisation device is fitted to the inlet to ensure optimal measurement precision.

They are available with or without displays, and with an M12 connector for powering and managing signals. The devices can be powered with a voltage that varies between 12 VDC (-10%) and 24 VDC (+30%). The versions with a display also have a temperature and pressure transducer which, thanks to an algorithm in the device's software, minimises measurement errors in the catalogue temperature range. All versions have IP65 protection.

The displays show values for flow rate, pressure and temperature, in addition to graphs for instantaneous and accumulated quantities.





Customer service

Extensive know-how and Metal Work Mechatronics's vast range of products combine ideally in providing top-level advice and customer service, both on the telephone and on site.

Our primary objective is to assist our customers in conceiving products and solutions that meet their requirements, whether it be a simple component, a motor or a compound system, such as the EB 80.

After-sales service is also guaranteed. A team of qualified service engineers, who use modern diagnostic and development tools, assist the customer on site or online during the commissioning of a machine or a system.

Training courses are regularly provided for our staff on various matters, especially on latest-generation products. Metal Work also organises in-house and external training and refresher courses for production plants and schools.

Our test laboratories are accessible to our customers for carrying out specific tests and the simulation of new applications.



Applications

Metal Work Mechatronics is a market player with specific skills in all industrial sectors dealing with automated mechanical engineering. Some of the numerous applications developed by our customers and co-engineered with our team of experts are shown here by way of example.



Our sales network.

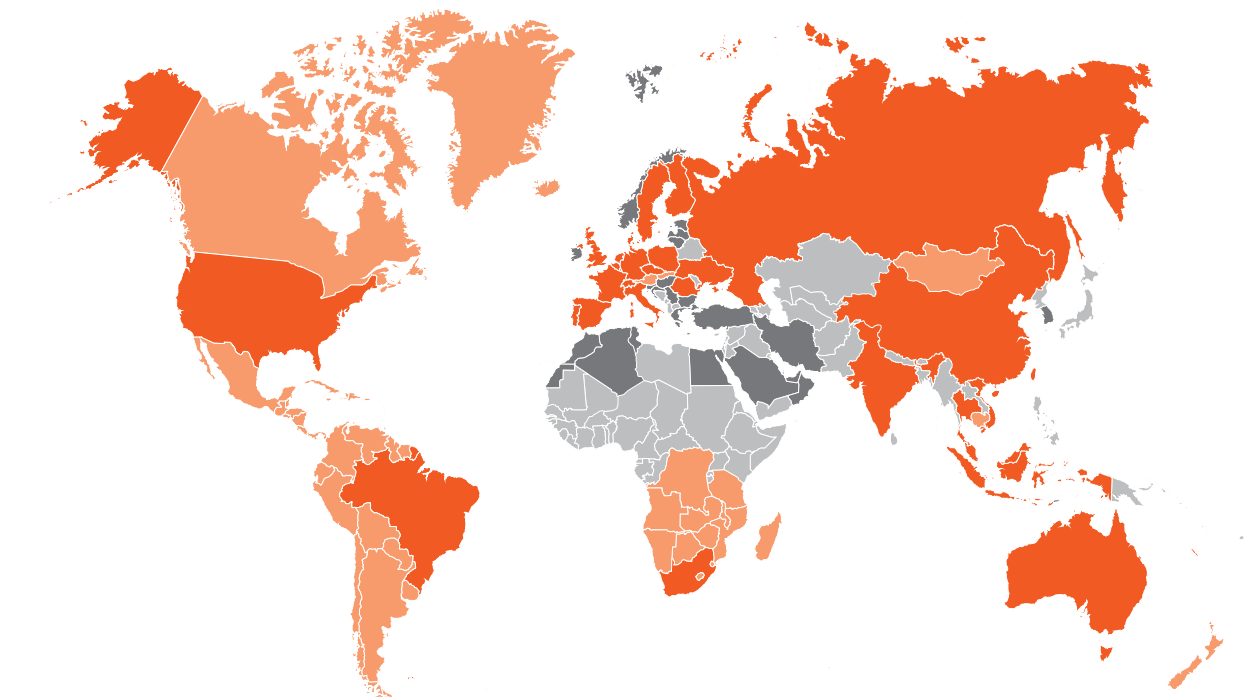

■ Group of companies Metal Work ■ Authorized dealer

Our subsidiaries in Italy



Bari
Bergamo
Bologna
Brescia
Cremona

Lecco
- Varese
Mantova
Modena
Monza Brianza

Novara
Parma
Prato
Rimini
Torino

Treviso
Verona
Vicenza

Our subsidiaries in the world



Australia
Belgio
Brasile
Cina
Danimarca
Finlandia
Francia

Germania
India
Indonesia
Malesia
Olanda
Polonia
Portogallo

Repubblica Ceca
Romania
Russia
Singapore
Spagna
Sud Africa
Svezia

Svizzera
Tailandia
Ucraina
Uk
Usa
Vietnam

